

SPEEDS	MPH	KIAS
V _{SO}	63 MPH	55 KIAS
V _{SO} (Flaps up)	72 MPH	63 KIAS
V _Y (Gear up)	100 MPH	90 KIAS
V _X (Gear up)	76 MPH	66 KIAS
V _A	138 MPH	120 KIAS
V _{LE} (EXT)	125 MPH	109 KIAS
V _{LO} (RET)	115 MPH	100 KIAS
V _{FE}	132 MPH	115 KIAS
V _{NO}	203 MPH	179 KIAS
V _{NE}	228 MPH	198 KIAS
Glide (2740 LBS)	105 MPH	90 KIAS
Glide (2300 LBS)	98 MPH	85 KIAS

BEFORE STARTING ENGINE	
Preflight Check	COMPLETE
Door / Baggage Door	LATCHED/LOCKED
Passenger brief	COMPLETED
Seatbelts	FASTENED
Controls	FREE & CORRECT
Circuit breakers	IN
Landing gear switch	DOWN position
Clock	SET
Radio master	ON
ATIS / Departure Clearance	RECEIVED
Radio master	OFF

STARTING ENGINE	
Ram air door	CLOSED
Cowl Flaps	OPEN
Alternate Static	OFF
Parking brake	SET
Fuel selector	LOWEST tank
Master switch	ON
Anti-collision	ON
Mixture	FULL RICH
Propeller	HIGH
Throttle	FULL
Boost pump	Count 3-5, then OFF
Mixture	IDLE CUT OFF
Throttle	1/4"
Propeller area	CLEAR
Starter	ENGAGE
Mixture	SMOOTH TO RICH
Throttle	1000 RPM
OIL PRESSURE	CHECK

STARTING ENGINE WHEN FLOODED	
Mixture	IDLE CUT OFF
Throttle	OPEN FULL
Boost pump	OFF
Starter	ENGAGE
Mixture	Advance
Throttle	retard to 1000

WARM UP	
Mixture	Lean aggressively
Engine Indicators	NORMAL
Fuel selector	FULL TANK
Avionic Master	ON
RADIOS	SET
Annunciators	PRESS to test
Autopilot	Flight Director ENABLE
Autopilot	TEST (4xRED FLASH)
Autopilot	ENGAGED
Autopilot	TRIM CHECK
Autopilot	HDG CHECK
Autopilot	DISENGAGE

TAXIING	
LIGHTS	as required
BRAKES	release, CHECK
COMPASS	swings freely
Attitude indicator	level attitude ±5°
Turn coordinator	correct turns/ball free
Directional gyro	moves with MC

Engine Runup Procedure	
BRAKES	SET, hold
MIXTURE	SET
THROTTLE	1800 RPM
PROP	cycle 3, leave HIGH
Magnetos	max drop 175 RPM max diff. 50 RPM
Suction	GREEN
Throttle	1000 RPM
Oil press/temp	NORMAL

Departure Briefing	
Runway	Length, Condition, Traffic
Rotate Speed	71 MPH (62 KIAS)
Climb out	Normal 100 MPH (90 KIAS) Obstacle 76 MPH (66 KIAS)
Landing Gear	Before 115 MPH (100 KIAS)
Departure	REVIEW

Review Emergency Procedures	
Engine failure during Takeoff:	
Throttle	IDLE
Brakes	APPLY
Mixture	IDLE, CUT OFF
Ignition Switch	OFF
Master	OFF
Engine Failure immediately after Takeoff:	
Airspeed:	100 MPH (87 KIAS)
Mixture	Idle, cut off
Fuel Selector	Off
Ignition	Off
Master	Off
NO HEADING CHANGES OF MORE THAN 30° BELOW 500FT!	

BEFORE TAKE OFF	
Door	LATCHED/LOCKED
Seat belts/harness	FASTENED
TRIM	SET for TAKEOFF
FLAPS	SET for TAKEOFF
Transponder	ACS-S, correct code
Flight instruments	SET (HDG/Alt)
IFR? Pitot Heat	ON
Boost pump	ON

CRUISE	
Boost pump	OFF
Flaps and Gear	UP
Cowl Flaps	CLOSED
Light	CHECK
Ram Air	OPEN when in Clear Air
Normal max. power	75%
Best ECONOMY	lean to: PEAK or LOP
Fuel	Switch tank

DESCENT	
Ram air door	CLOSED
Mixture	ENRICHEN
Fuel selector	FULLEST tank

Approach Briefing	
Wind Weather Runway Review Approach	
VFR	IFR
Traffic Pattern:	IAP: Navaid, Course, FAF,
Entry, Altitudes,	Descent Path, Airspeed, Time to
Airspeed	Fixes, DA / MDA, Visual Descent Point, Missed Approach and Intentions
Review Speeds	Flaps 132 MPH (115 KAS) Gear 125 MPH (109 KIAS) Pattern: 98 MPH (85 KIAS) Final: 81 MPH (71 KIAS)

APPROACH AND LANDING	
Landing light	as required
Fuel	Fullest Tank
Flaps	max 132 MPH (115 KIAS)
Landing Gear	DOWN, 125 MPH (109 KIAS)
Mixture	SET
Propeller	HIGH
Fuel Pump	ON
Ram Air	CLOSED
Seat belts/harness	FASTENED
Seat backs	ERECT
Airspeed	Final 81 MPH (71 KIAS)
Final	CHK GEAR DOWN

AFTER LANDING	
Pitot Heat	OFF
Flaps	UP
Cowl Flaps	OPEN

STOPPING ENGINE	
Transponder	7000 SBY
Flaps	UP
Trim	SET for TAKEOFF
Lights	OFF
Radio Master	OFF
Throttle	1200 RPM
Propeller	HIGH
Mixture	IDLE CUT OFF
Master	OFF
Magnetos	OFF

PARKING	
Overhead Air Scoop	CLOSED
Control wheel	SECURE with seatbelt
Door/luggage door	LOCKED
Tie downs	SECURE
Flight plan	CLOSED

ENGINE POWER LOSS IN FLIGHT	
Airspeed	best glide, 105 MPH (90 KIAS)
Mixture	full RICH
Boost pump	ON
Fuel selector	Tank WITH FUEL
Propeller	LOW PITCH
Cowl Flaps	CLOSED
GLIDING DISTANCE: 2 NM per 1.000 ft	

FIRE IN FLIGHT			
ELECTRICAL		ENGINE	
Master switch	OFF	Mixture	CUT OFF
Vents	OPEN	Boost pump	OFF
Storm window	OPEN	Throttle	CLOSED
Heat/defrost	OFF	Fuel selector	OFF
Circuit Breaker	CHECK	Heat/defrost	OFF

FAILURE of ELECTRICAL LANDING GEAR	
Slow Aircraft	125 MPH (109 KIAS)
Gear Circuit Breaker	OFF
Gear Switch	DOWN Position
Handcrank	Push FORWARD
Handcrank	crank clockwise
Gear Annunciator	GREEN
Visual Gear Down Indicator	CHECK GREEN



Preflight Inspection

Cockpit/Cabin

Magneto / Starter	OFF
Radio Master	OFF
Gear Switch	DOWN
Master switch	ON
Landing gear light	"Gear Down"
Annunciator lights	press to test
Gyro	Listen, spooling?
Fuel gauges	CHECK, note quantity
OUTSIDE LIGHTS	CHECK
Master Switch	OFF
Fuel Selector Drain	Pull on Both 5 sec.
Controls	FREE

8)	RIGHT Side COWLING	CLOSED
	ENGINE OIL LEVEL	CHECK
9)	FUEL TANK	CHECK QUANTITY
	FUEL TANK DRAIN	SAMPLE
	TANK VENT	FREE
	RIGHT MAIN GEAR	CHECK
	TIE DOWN	REMOVE
10)	LEFT WING SKIN	CHECK
	WING TIP STROBE	CHECK
	AILERON AND FLAP	CHECK
11)	BAGGAGE DOOR	SECURE

Outside

1)	RIGHT STATIC PORT	FREE
2)	TAIL Tiedown	REMOVE
	EMPENNAGE	CHECK
3)	LEFT STATIC PORT	FREE
	TAIL CONE ACCESS DOOR	SECURE
	STATIC SYSTEM DRAIN	CHECK
4)	LEFT WING SKIN	CHECK
	FLAP and AILERON	CHECK
	WING TIP STROBE	CHECK
	TIE DOWN	REMOVE
5)	PITOT TUBE and STALL SWITCH	CHECK
	FUEL TANK	CHECK QUANTITY
	FUEL TANK DRAIN	SAMPLE
	PITOT SYSTEM DRAIN	CHECK
	TANK VENT	FREE
	FUEL SELECTOR DRAIN VALVE	CLOSED
	LEFT MAIN GEAR	CHECK
6)	WINDSHIELD	CLEAN
	LEFT Side Cowling	CLOSED
7)	PROPELLER	CHECK
	RAM Air Door	CHECK CLOSED
	LANDING LIGHT	CHECK
	NOSE GEAR	CHECK
	CHOCKS	REMOVE

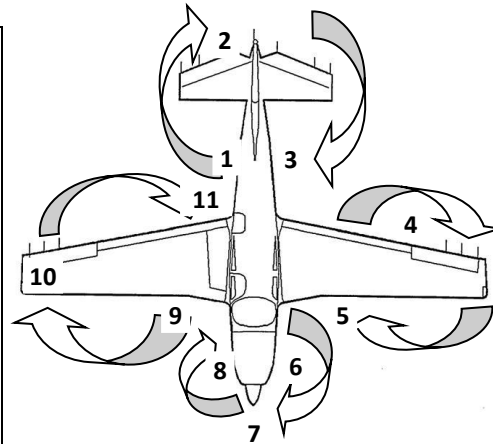

Power Setting Table - Lycoming Model IO-360-A1B6D, 200 HP

Pressure Altitude (feet)	Std Temp. °F/°C	110 HP - 55% RPM & Man Press		130 HP - 65% RPM & Man Press		150 HP - 75% RPM & Man Press		Pressure Altitude (feet)
SL	59/15	21.0 -2400	22.5 -2200	21.8 -2600	24.0 -2400	24.7 -2600	25.9 -2500	SL
1000	55/13	20.7 -2400	22.3 -2200	21.7 -2600	23.8 -2400	24.6 -2600	25.8 -2500	1000
2000	52/11	20.4 -2400	22.2 -2200	21.6 -2600	23.6 -2400	24.4 -2600	25.6 -2500	2000
3000	48/9	20.3 -2400	22.1 -2200	21.5 -2600	23.4 -2400	24.4 -2600	25.5 -2500	3000
4000	45/7	20.2 -2400	22.0 -2200	21.5 -2600	23.3 -2400	24.4 -2600	25.4 -2500	4000
5000	41/5	20.1 -2400	21.9 -2200	21.4 -2600	23.0 -2400	24.2 -2600	25.3 -2500	5000
6000	38/3	20.0 -2400	21.8 -2200	21.3 -2600	22.8 -2400	24.1 -2600		6000
7000	34/1	19.9 -2400	21.9 -2200	21.3 -2600	23.0 -2400	23.8 -2600		7000
8000	31/-1	19.8 -2400	22.0 -2200	21.2 -2600	23.1 -2400	23.6 -2700		8000
9000	27/-3	18.4 -2600	19.7 -2400	21.2 -2600				9000
10,000	23/-5	18.3 -2600	19.5 -2400	21.1 -2600				10,000
11,000	19/-7	18.3 -2600	19.4 -2400	20.0 -2700				11,000
12,000	16/-9	18.2 -2600	19.3 -2400	19.8 -2700				12,000
13,000	12/-11	18.0 -2600	19.3 -2400					13,000
14,000	9/-13	17.8 -2600	19.2 -2400					14,000

Fuel Consumption Approximations

75% Best Power 11.5 GPH 65% Best Power 10.5 GPH 55% Best Power 10.0 GPH
 75% Best Economy 10.0 GPH 65% Best Economy 9.5 GPH 55% Best Economy 8.5 GPH

Best power = 50° C rich of peak EGT Best Economy = Peak EGT (or LOP)

To maintain constant power, correct manifold pressure approximately 0.15" Hg for each 10° variation in temperature from standard altitude temperature.

ADD manifold pressure for air temperatures above standard; SUBTRACT manifold pressure for temperatures below standard.