

SUBJECT: MAIN LANDING GEAR RETRACTING LINK BOLT REPLACEMENT

## MODELS

AFFECTED: M20F - S/N 660003 thru 22-1439  
M20J - S/N 24-0001 thru 24-0609

## TIME OF

COMPLIANCE: MANDATORY compliance within 90 days of notification.

## INTRODUCTION:

To prevent the possibility of failure of the main landing gear side brace during adverse ground conditions the side brace bolts are to be replaced for greater capabilities.

## SPARE PARTS

## REPLACEMENT:

Effective on the date of this Service Bulletin all bolts to be used on noted aircraft will be of the higher strength NAS type.

## INSTRUCTIONS:

Replace bolts in main landing gear retraction link and truss:

NOTE: Hardware that does not have a replacement is to be retained for reinstallation after visual inspection.

1. Place aircraft on jacks and partially retract gear by placing gear switch in up position and turn master switch off to stop gear. Then pull circuit breaker.
2. Disconnect main gear doors.

NOTE: Steps 3 thru 12 apply to both left and right main gear and should be performed one gear at a time. Refer to Figure 212-1 for proper orientation.

3. Remove bolt at position B, attaching tube to retraction truss. Retain for re-installation.
4. Remove bolt at position A, attaching retracting truss to fitting.
5. Remove nut from bolt attaching link to main landing gear at position C.

NOTE: Step 6 thru 9 will require two people to perform, one to hold gear in proper position and one to remove and install bolt in main landing gear and link. CAUTION must be taken to keep forward attach point of gear from slipping out of its bearing while rear attach point is disconnected. If forward attach point does slip out then the retracting spring must be removed before the gear can be re-installed. (Refer to Service & Maintenance Manual.)

## Instructions Cont...

6. Remove four bolts from rear attachment bracket and slide gear and bracket outboard and upward into outboard corner of wheelwell.
7. With rear attach point of gear held in corner of wheelwell retract gear about 15° or until bolt attaching retracting link to gear can be removed.
8. Install NAS 1306-29 bolt (2.3 inches long) in main landing gear re-attaching retracting link while gear is held in canted position.
9. Slide rear attach point of gear and rear attach bracket back into place and install the four attaching bolts.
10. Install new AN 363-624 nut (and washer as required) on main landing gear attaching link, position C.
11. Install NAS 1306-20H or 1306-21H bolt as required thru retracting truss and fitting, position A. (Re-safety wire).
12. Re-install bolt, washer and nut thru tube and retracting truss, position B.

## CHECK INSTALLATION:

1. Retract gear for check of proper operation and clearances.
2. Reconnect main gear doors and check for preload torque and proper rigging. Refer to Service and Maintenance Manual.
3. Place gear in down and locked position and remove aircraft from jacks.
4. Aircraft is ready for return to service.
5. Make Log Book entry and fill out Compliance Card.

## S.B. Kit No. M20-212-1 (M20F):

NAS 1306-20H Bolt . . . . . 2 ea.  
 NAS 1306-21H Bolt . . . . . 2 ea.  
 (NOTE: Use correct grip length as required.)  
 NAS 1306-29 Bolt . . . . . 2 ea.  
 AN 363-624 Nut . . . . . 2 ea.

## S.B. Kit No. M20-212-2 (M20J):

NAS 1306-21H Bolt . . . . . 2 ea.  
 NAS 1306-29 Bolt . . . . . 2 ea.  
 AN 363-624 Nut . . . . . 2 ea.

This Service Bulletin kit may be purchased from your local Mooney Marketing or Service Center. Direct factory orders will not be accepted.

FIGURE 212-1

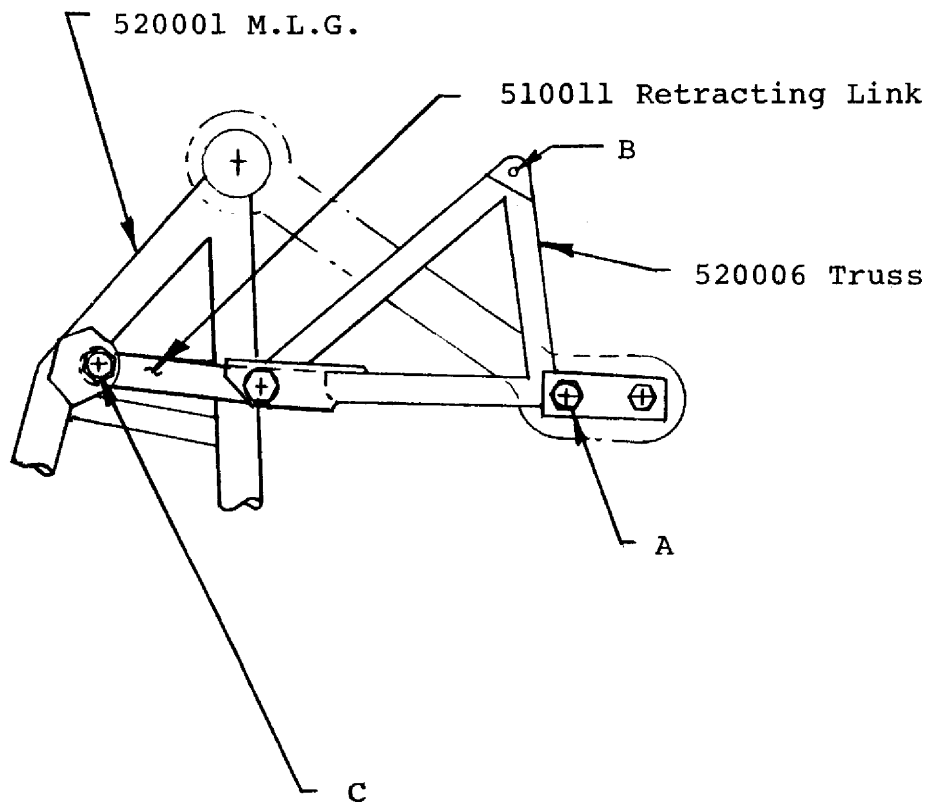

Main Landing Gear Retraction System  
(View Looking Aft from Front of Right Gear)

- A. Remove AN6H-17A or 914006-503 bolt.  
Install NAS 1306-21H or 1306-20H bolt  
as required.
- B. Retain hardware for re-installation.
- C. Remove AN6-22A bolt.  
Install NAS 1306-29 bolt (2.3 inches long)  
and new AN 363-624 nut.