



NUMBER: M20-45

DATE: 7-17-79

SUBJECT: INSTALLATION OF MECHANICAL DOWN STOP TO BOTH SIDES OF AVIONICS PRODUCTS ACTUATOR, P/N 102000

MODELS/
SERIAL NUMBERS
AFFECTED:

M20J, 24-0378 thru 24-0772
M20K, 25-0001 thru 25-0052

TIME OF
COMPLIANCE:

At next annual or 100 hr. inspection, whichever occurs first.

INTRODUCTION:

The early model M20J and M20K aircraft had only one down stop installed during manufacture and some indications have been that the worm gear shaft is binding, when gear is extended manually, as it comes in contact with the one down stop provided. A bending action is taking place and in some cases, locking the shaft up tight so the gear will not retract when desired. To eliminate this situation it is recommended that a second down stop be added to the above aircraft to provide equal loads on the actuator ball nut.

INSTRUCTIONS:

1. Jack aircraft and remove belly access panel P/N 310124 located behind the nose wheel well (2nd panel back).
2. Measure thickness of existing stop installed. Using P/N 560252-9 stop and P/N 560252-11 shims match thickness of existing stop using information in step 3 below.
3. The number of shims required to match the rigged dimension are as follows: These are in addition to 1 ea. 560252-9 down stop. The screw lengths required are also listed.

<u>Original Stop Dimension</u>	<u>Number of Shims</u>	<u>Screw P/N's</u>
.188	Zero	Zero
.250	1	AN515-6R4
.313	2	AN515-6R5
.375	3	AN515-6R6
.440	4	AN515-6R7

4. Partially retract gear and install the proper down stop/spacer combination as shown in Figure 1.

Instructions cont...

5. With gear fully extended, check clearance between down stops and end of ball nut. This should be .050 to .100 inches.
6. Cycle gear electrically through at least (5) five trouble free operations.
7. If rigging is out of adjustment refer to Service and Maintenance Manual Procedures, paragraph 5-6A, M20J; and paragraph 5-7, M20K.
8. Reinstall belly panels and enter compliance record into Aircraft Log Book.

REFERENCE
DATA:

1. M20J - Service and Maintenance Manual No. 106, Paragraph 5-6A.
2. M20K - Service and Maintenance Manual No. 108, Paragraph 5-7.

PARTS
LIST:

S.I.20-45-1 Kit

	<u>Quantity</u>	<u>Part Number</u>	<u>Description</u>
1)	1	560252-9	Down Stop
2)	4	560252-11	Shims
3)	2	AN515-6R4	Screw
4)	2	AN515-6R5	Screw
5)	2	AN515-6R6	Screw
6)	2	AN515-6R7	Screw

S.I.20-45-2 Kit

1)	1	#83-31 Grade C	Loctite (10CC)
----	---	----------------	----------------

FIGURES/
TABLES:

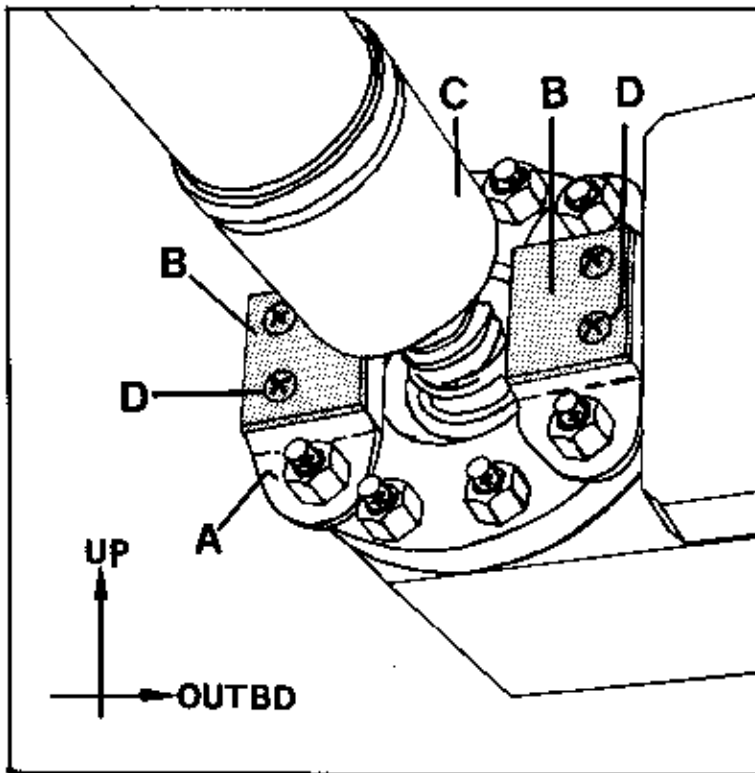

Figure 1 Mechanical Down Stop

- A. 560252-9, Down Stop
- B. 560252-11, shim. (use with 560252-9, down stop only, max. of 4 on each side).

NOTE: Use 1 to 4 560252-11 shims with 560252-9 stop to achieve proper clearance as an alternate for 560252-1, -3, -5 and -7.

- C. Actuator Ball Nut
- D. AN515-6R4 Screw*
AN936A6 Lock Washer
(Typ. 2 plc.) (use with 560252-9 only)

*Use .063 longer screws with each additional shim. (Secure screw with Blue Locktite #83-31 grade C).