

SUBJECT: MOONEY M20J & M20K AIRCRAFT, IMPROVED SEALING OF TAILCONE AREA TO REDUCE WATER INGESTION WHILE FLYING THRU RAIN

**MODELS/
S/N AFFECTED:** M20J S/N 24-1418 thru 24-1588
M20K S/N 25-0781 thru 25-1035

TIME OF COMPLIANCE: At owner's discretion.

INTRODUCTION: Reports have been received concerning malfunction of some types of avionics equipment shortly after flight through heavy rain. Evaluation of units in question determined water had caused the malfunction. Tests were conducted on instrumented aircraft and water was observed to enter the tailcones of some aircraft through various openings. This Service Instruction and related kit components will allow the owner, if desired, to seal the areas observed in the tailcone.

INSTRUCTIONS:

I. Fuselage lower belly fairing.

A. Seal the lower fairing (fiberglass belly skin) P/N 310322-501 as follows:

1. Remove lower belly fairing.
2. Apply release agent (i.e. Johnson Wax, oil film) to outer 1" of peripheral edges of fairing.
3. Apply a bead of PR 1422-B2 sealant to fuselage mounting surface; carefully install lower fairing utilizing all attaching points.
4. Allow sealant to cure (ref. S & M fuel section for cure times vs. temperatures).
5. Remove fairing, clean off release agent and reinstall.

II. Tailcones - various areas.

A. Battery box air scoop:

1. Remove avionics bay access cover from L.H. side of tailcone.
2. Refer to Figure SI M20-76-1 for sealing instructions.

CAUTION

Use isopropyl alcohol to clean scoop; other cleaners may damage plastic material.

NOTE

Some configurations may require equipment or wiring to be relocated during the sealing procedure.

B. Tailcone drain holes at Fus. Sta. 108.00 and 130.00

FUSELAGE STATION 130.00

1. Obtain access through avionics bay access opening. Locate hole just aft of bulkhead (Sta. 130.00) and on either side of fuselage center line.
2. Degrease area around drain holes from inside tailcone. Do not allow degreaser to contact paint on outside of tailcone.
3. Apply PR 1422-B2 sealant liberally to completely fill these two drain holes.
4. Allow sealant to cure completely.
5. Carefully remove extruded sealant (if any) from outside surface of tailcone skin with sharp knife or razor blade.
6. Refer to Figure SI M20-76-2 for location.

Instruction cont . . .

FUSELAGE STATION 108.00

1. Refer to Figure SI M20-76-2 for location.
2. Drill out one existing rivet on center line of tailcone bottom per Fig. SI M20-76-2.
3. Place fairing, P/N 210231-3, into position as shown in Figure 76-2 on outside belly skin and cleco fairing to skin through center line hole. Drill the four remaining holes (#40 drill) through belly skin.
4. Remove fairing, clean and deburr all holes.
5. Install fairing, using MS 20470AD3 rivet or equivalent of proper length.
6. Touch up fairing and reworked area with proper paint to match aircraft.

C. Tailcone aft bulkhead - Fuselage Sta. 199.5

1. Remove tailcone/empennage fairings P/N 470002-XX.
2. Refer to Figure SI M20-76-3 for location and instructions for filling void.
3. Allow sealant to cure.
4. Reinstall fairings, 470002-XX.

D. Tailcone - auxiliary power plug or oxygen system service access doors (if installed)

1. Auxiliary power plug access door (if installed) is located on avionics bay access panel.
2. Oxygen system servicing access door (if installed) is located on the tailcone aft and below the baggage door.
3. Refer to Figure SI M20-76-4 for installation of the seal, P/N 950006-015, and retainer, to either of the doors.
4. Place foam seal, adhesive side to doubler, inside access door to cover all gaps created by spring loaded door hinge assy (View No. 1). Place cut portion of seal as shown in View #2.
5. Retainer plate, make from .032, 2024-T3 material 2.00 in. x 1.00 in., should be riveted on top of seal inside access cavity to hold seal tightly in place. Use proper length AVEX blind rivet to attach retainer. Rivet hole location shown in View No. 2 is approximate. **DO NOT DRILL** into door spring or hinge pin when installing rivet.
6. Touch up rivet to match aircraft paint.

E. Seal avionics bay access cover, P/N 913014-503, as follows:

1. Remove access cover from L.H. fwd. side of tailcone.
2. Degrease access cover mounting flange on tailcone.
3. Apply release agent (i.e., Johnson Wax, oil film) to outer $\frac{1}{8}$ " of peripheral edges of access cover.
4. Apply bead of PR 1422-B2 sealant to mounting flange on tailcone; carefully install access cover using all fasteners.
5. Allow sealant to cure (ref. S & M Fuel Section for cure times vs. temperatures).
6. Remove access cover, clean and reinstall.

REFERENCE DATA:

N/A

PARTS LIST:

Kit P/N SI M20-76-001

| P/N | Description | Qty. |
|---------------|-------------|------|
| 1. PR 1422-B2 | Sealant | 2 |
| 2. 210231-003 | Fairing | 1 |
| 3. 950006-015 | Seal, Foam | 2 |

FIGURES/TABLES:

See next pages for Figures SI M20-76-1 thru -4.

BATTERY BOX

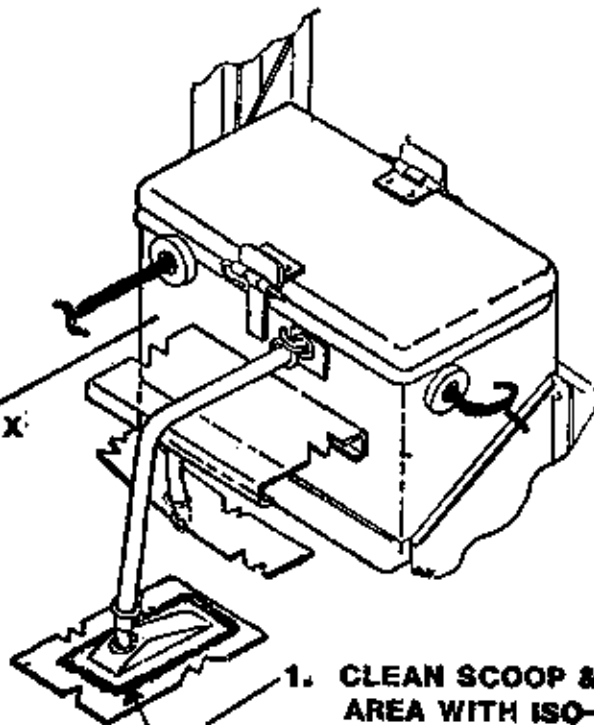

1. CLEAN SCOOP & ADJACENT SKIN AREA WITH ISO-PROPYL ALCOHOL.
2. APPLY PR1422-B2 SEALANT AROUND SCOOP & SKIN.

FIGURE SI M20-76-1

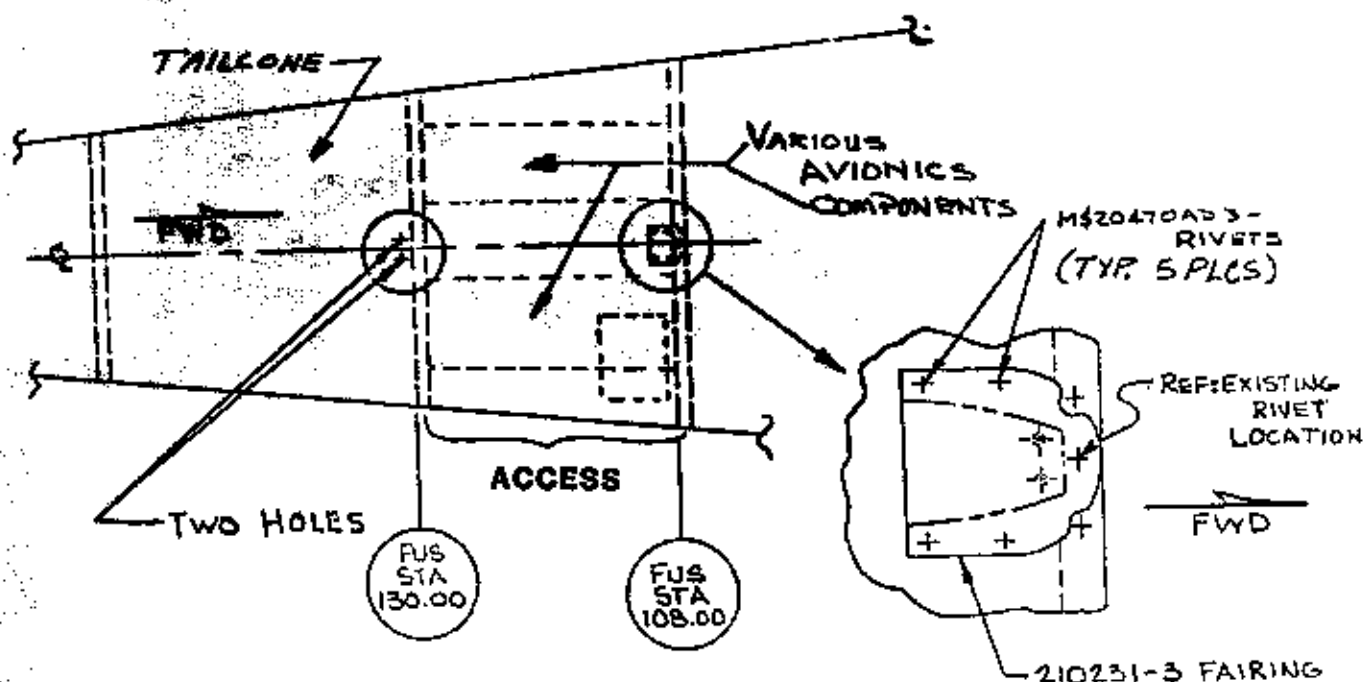

FIGURE SI M20-76-2

VIEW LOOKING UP (FROM FLOOR)

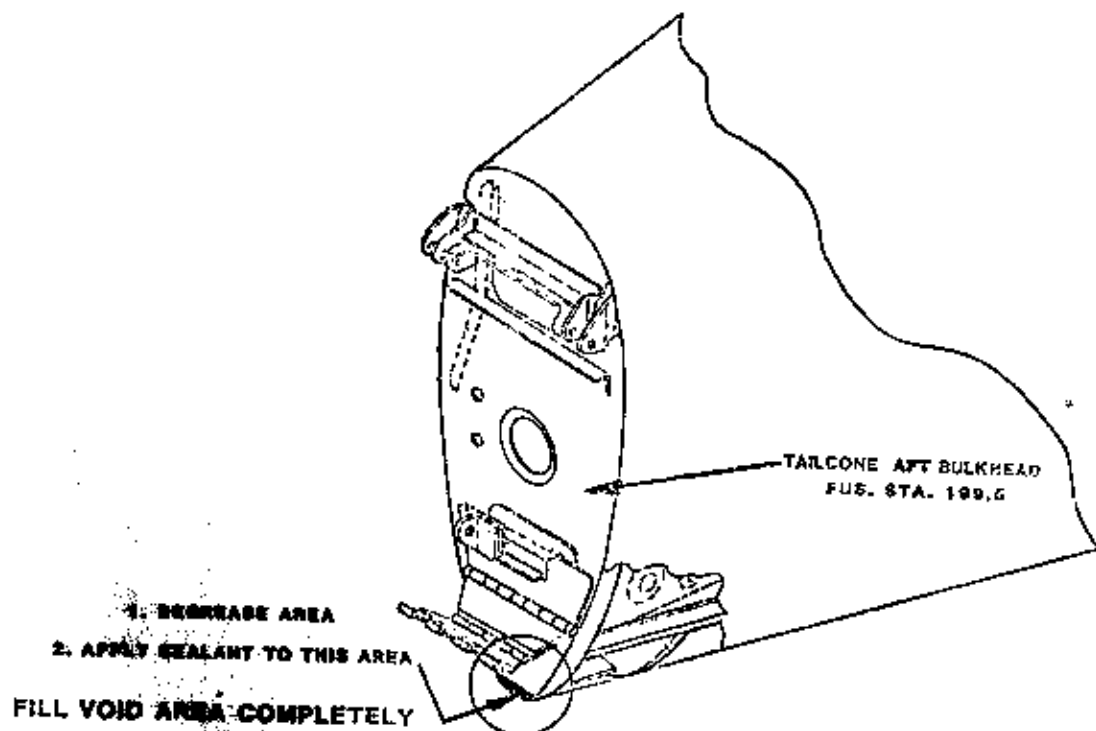

FIGURE SI M20-76-3

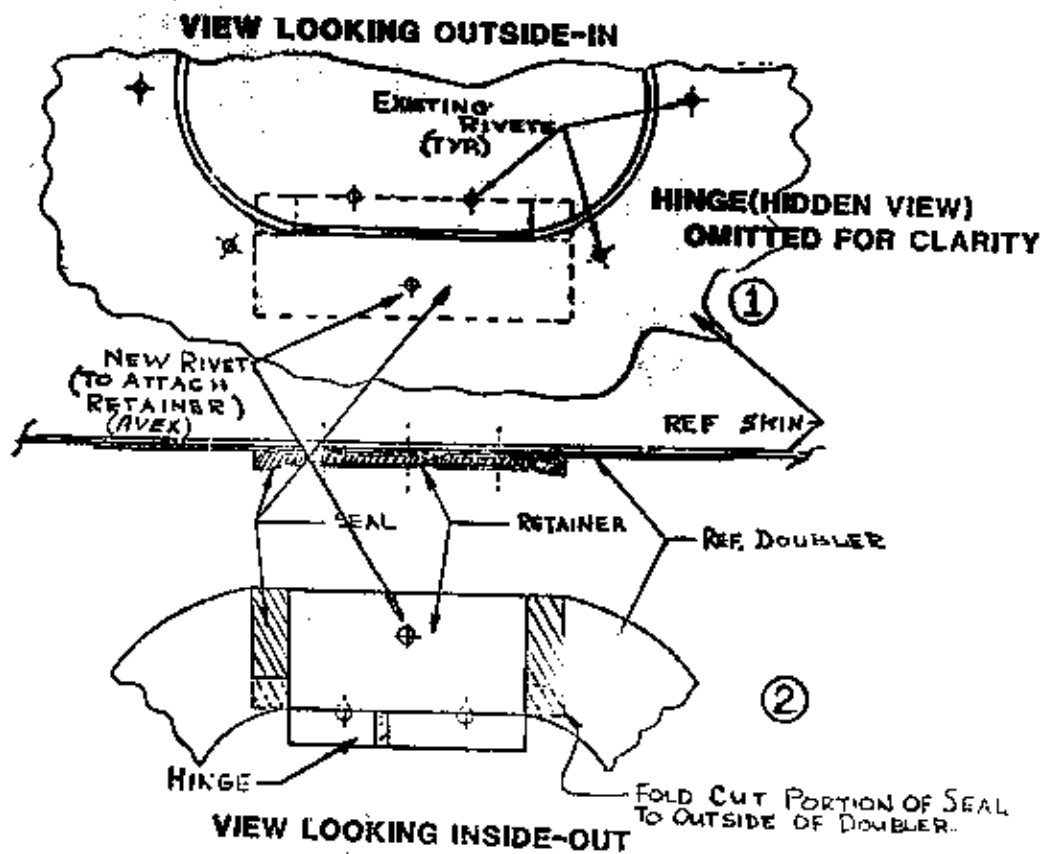

FIGURE SI M20-76-4